

Documentation V 1.0

Art. Nr: S-24903

Steel **KNX** Dimmer-Sequencer-Actuator



Short description

Art. Nr. S-24903

Fitting and assembly of electrical appliances must only be done by an electrician. Inadherence to the installation instructions could result in fire or other dangerous consequences. The Dimmer-Sequencer-Actuator is a protection rating III device. Be sure that the voltage in the KNX and the primary side correspond to the SELV- values.

Caution:

During installation and maintenance, measures must be taken to prevent a polarity reversal of the supply voltage.

The Dimmer-Sequencer-Actuator 12/24VDC STEEL/KNX is a bus-compatible 3 channel dimmer for use with a KNX/EIB bus. The actuator serves to operate LED lighting devices that are operated by a controlled voltage. The device is designed principally with the operation of RGB lighting in mind, for example to create colourful lighting effects or to run a pre-programmed colour cycle.

Input connections, refer to the illustration:

- (1) 24VDC terminals for the supply
- (2) KNX terminals

Output connections, refer to the illustration:

- (5) RGB LED channels

Switches and buttons on the device:

- (6) Programming button to program the address
- (7) LED signal lights

Technical data

Supply voltage	12-24 V DC
Max. output voltage	2,2 A / channel
Connection load	12V DC 80W 24V DC 155W
Output short circuit protection	YES
Reverse polarity protection	YES
KNX transfer rate	250.000 Bps
KNX current consumption	Max. 12mA
Working temperature	-5 °C bis +45 °C
Connections	KNX / EIB load by means of single wire 0,75-1,5mm, screw terminals
Output signal	PWM / 600Hz

Note:

In order to prevent malfunction, the maximum cable length, supply points, maximum distances etc. must be observed.

Warranty

We provide a guarantee in accordance with the law. Please send the device (free postage) to our central customer service centre, with a description of the fault.

Function

The dimmer-sequencer-actuator connects high performance LEDs with the KNX/EIB bus. The device can be addressed by the KNX bus and has a program button for this purpose.

Dimmer-Sequencer-Actuator wiring diagram

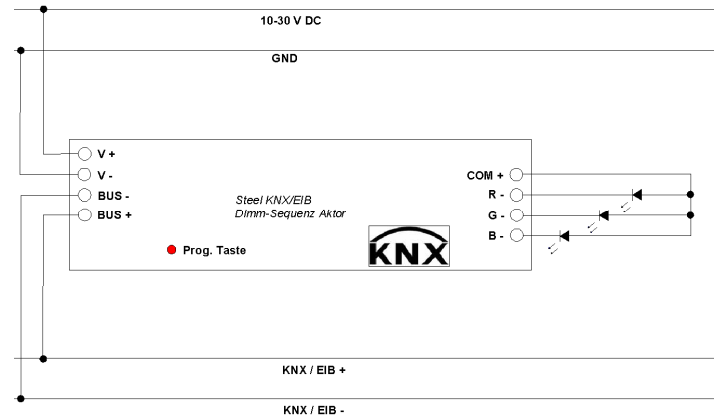

Operating modes:

In the case of interruption in bus voltage:

The device is inactive and cannot be operated. The most recent mode of operation is present at the outputs.

In the case of resumption of the bus voltage:

The device is initialised. During the initialisation procedure the outputs are switched on one after the other for a short time. Then the most recent value is loaded.

In the case of interruption in supply voltage:

Operation remains active. LEDs do not function.

The device is programmable by means of the engineering tool ETS2 V1.3 or higher, or the ETS3. You can find the database of products on our homepage: www.BILTON.at under KNX TOOLS. The handbook is also to be found at this address, with a detailed description of the programming procedure.

After successful programming of the device in the KNX bus, the device undergoes an initialisation process, during which the individual outputs are switched on and off in succession.

If the device is addressed but still has no application program loaded, then after initialisation the device is in no definite mode. It is then possible that until an application is loaded, the outputs are switched on and the lighting is active. Unintentional activation of the lighting can be avoided by turning off the supply voltage.

HEAD OFFICE

Customer Service Centre:

BILTON LED LIGHTING
 Loferer straÙe.2
 5760 Saalfelden/ Austria
 Tel: +43 6582 71164
 Fax: +43 6582 71164 -10
 service@bilton.at

Produced and tested by:
 Micro Systeme GmbH
 Hirnreit 113
 5771 Leogang

Contents

CONTENTS.....	3
1 GENERAL	4
2 TECHNICAL INFORMATION	4
2.1 TECHNICAL DETAILS.....	4
2.2 WIRING DIAGRAM	5
2.3 SPECIAL MODES OF OPERATION	5
2.3.1 Interruption in bus voltage	5
2.3.2 Resumption of bus voltage	5
2.3.3 Interruption in 12 or 24V DC supply	5
3 SOFTWARE DESCRIPTION	6
3.1 OVERVIEW.....	6
3.1.1 Software functions.....	6
3.2 GENERAL PARAMETER DEFINITION.....	7
3.2.1 Parameter window: general.....	7
3.2.2 Parameter window: dimming.....	10
3.2.3 Parameter window: value	12
3.3 COMMUNICATION PROPERTIES	15
3.3.1 General properties.....	15
3.3.2 Scene control.....	16
3.3.3 Colour cycle	16

1 General

The dimmer sequencer 12/24V DC Steel / KNX is a KNX/EIB bus-compatible 3 channel dimmer. The actuator controls LED, voltage-controlled lighting devices. The actuator is designed with the control of RGB lighting particularly in mind, for example to create colour lighting or to run a pre-programmed colour cycle.

2 Technical information

2.1 Technical details

Supply	KNX supply KNX current consumption	21...40V DC, polarity protected Max. 12mA
	Output supply voltage Output current consumption	10 – 30VDC polarity protected 6,6A
Ausgänge	3 outputs, pulse width modulated voltage driven	Maximum current per channel 2,2A Short circuit protection PWM Frequency 600Hz
Connections	KNX	Bus connection terminal
	Input for load circuit	Screw terminals Single wire 0.75-1.5 mm ²
	Outputs	Screw terminals Single wire 0.75-1.5 mm
Operation	KNX	1 program button 1 red LED, red, to show if the address status is active.
Cable length	Outputs	Maximum
Installation instructions	Installation position	Not relevant
	Location	Indoors only
	Cooling	Enough cooling is required in order not to exceed the maximum working temperature.
Working temperature range	Operation	-5....+45°C

2.2 Wiring diagram

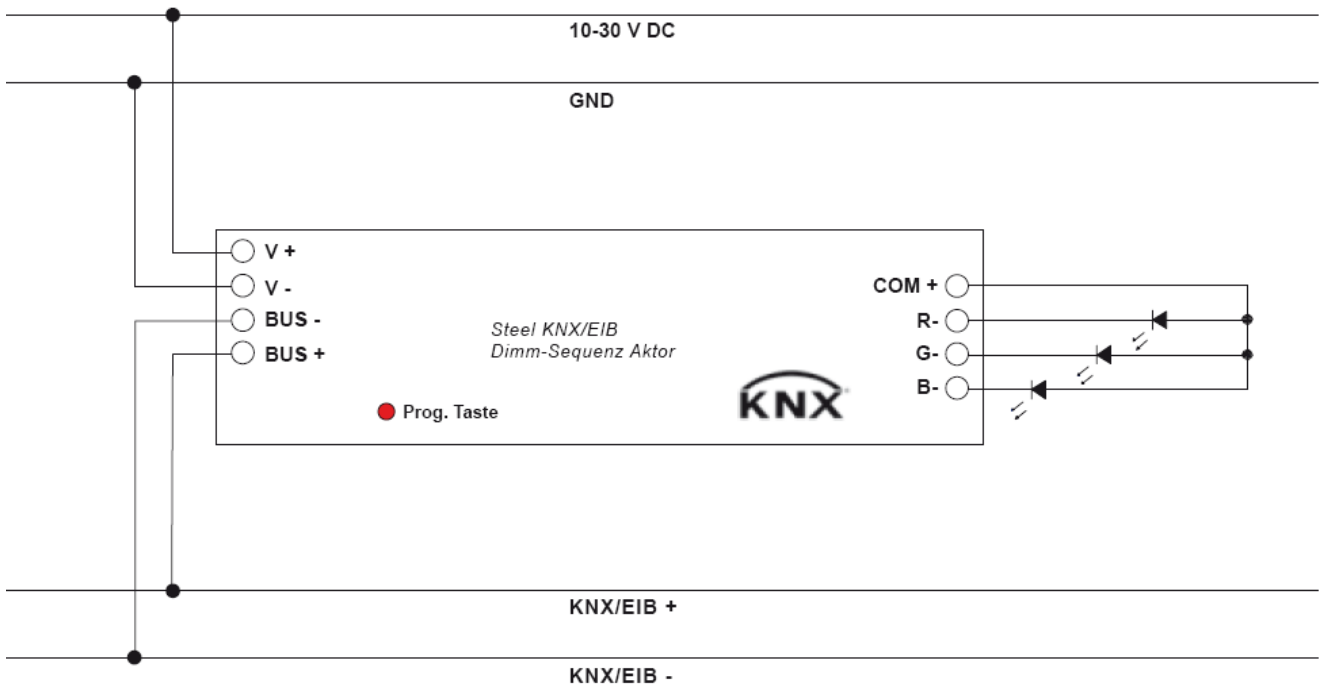

2.3 Special modes of operation

2.3.1 Interruption in bus voltage

The device is inactive and cannot be operated. The most recent mode of operation is present at the outputs.

2.3.2 Resumption of bus voltage

The device is initialised. During the initialisation procedure all three outputs are switched on and off one after the other for a short time. Then the most recent value is loaded.

2.3.3 Interruption in 12 or 24V DC supply

Operation of the dimmer actuator remains active. Connected LEDs cannot be operated.

3 Software description

3.1 Overview

The application program LAXD_KNX_3CHCOMB_1.0 is the basis program for controlling the unit. It gives the basic functions to enable dimming of the relevant outputs.

The tool TES2 V1.3 is needed to program the unit. If ETS3 is used, then it is necessary to use data with the suffix *.vd3.

Up to date software is pre-loaded prior to delivery. In order to reload the software, the old software needs to be removed and then the new software loaded by means of the bus. This may take some time.

3.1.1 Software functions

Main function	Description
Switching	<ul style="list-style-type: none"> • Gives the switching on value • Dimming rate for switching on and off • Delay time in switching on and off
Dimming	<ul style="list-style-type: none"> • Adjustable dimming rate • Adjustable minimum and maximum dimming limits • Possible parametering of switching on and off using relative dimming
Brightness	<ul style="list-style-type: none"> • Adjustable dimming rate to a specified value using the dimming rate parameter • Adjustable minimum and maximum values
Scenes	<ul style="list-style-type: none"> • Using "scene control", you can predefine up to 11 colour scenes for the RGB outputs • Scenes can be recalled using the relevant scene number
Colour cycle	<ul style="list-style-type: none"> • Start and stop a predefined colour cycle • Define the duration of a colour cycle

3.2 General parameter definition

The parameters described here correspond to all three outputs in each category. The outputs are not treated separately.

3.2.1 Parameter window: general

Higher order parameters are found in this window.

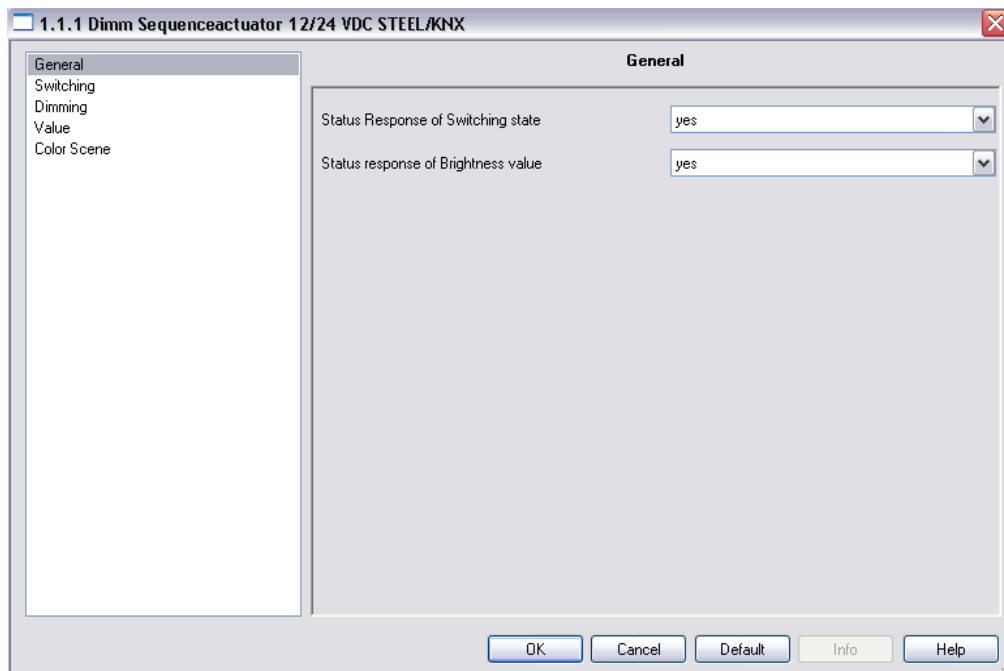

Status response of switching state

Options: Yes
 No

Here you can set whether the additional property for the feedback of the switching status for all outputs should be activated or not.

Status response of brightness value

Optionen: Yes
 No

Here you can set whether the additional property for the feedback of the brightness value should be activated.

Parameter window: switching

In this window the behaviour of the device is set if the device is operated with the “switching” parameter.

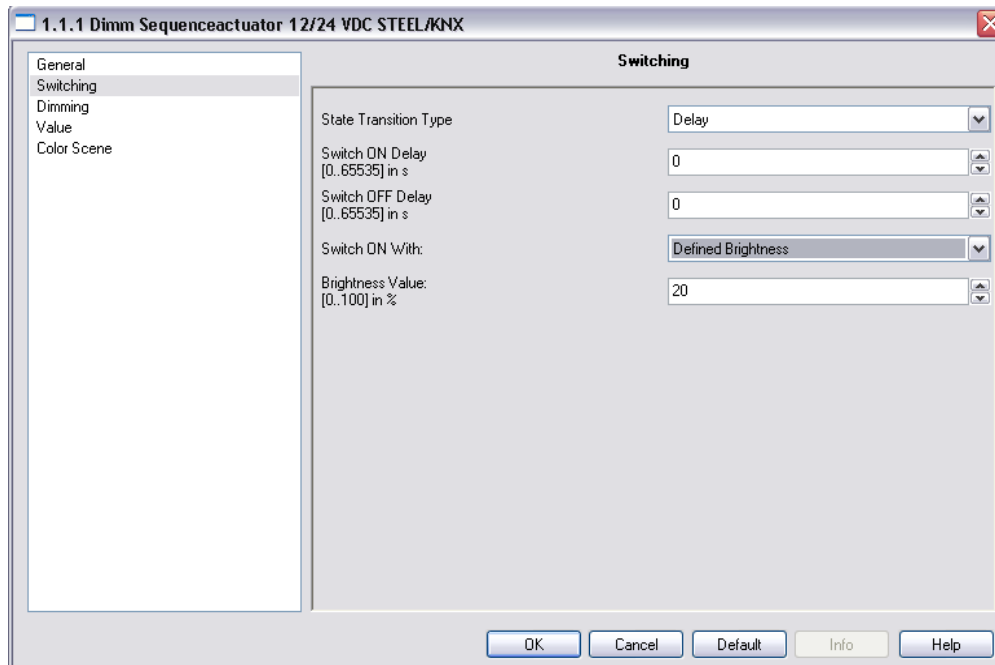
**State transition type**

Options: *delay*
dimming

- Delay means the start is delayed or switched off
- Dimming means that the outputs dim to the corresponding final value

Delay in switching on

Options: *Value between 0 and 65535 seconds*

Displays the delay time with which the outputs are turned on. This parameter is only active when the switching transition is set to “delay”.

0 corresponds to an immediate transition to the final value.

Delay in switching off

Options: *Value between 0 and 65535 seconds*

Displays the delay time with which the outputs are turned off. This parameter is only active when the switching transition is set to “delay”.

0 corresponds to an immediate transition to the final value.

Switching on with

Options: *last level of brightness*
 fixed level of brightness

You can select to switch on either with the last brightness level or with a fixed, predetermined, brightness level.

Brightness level

Options: *Value between 0 and 100%*

This value is only possible in the parameter “switch on with a fixed brightness”. The brightness level for switching on is displayed here.

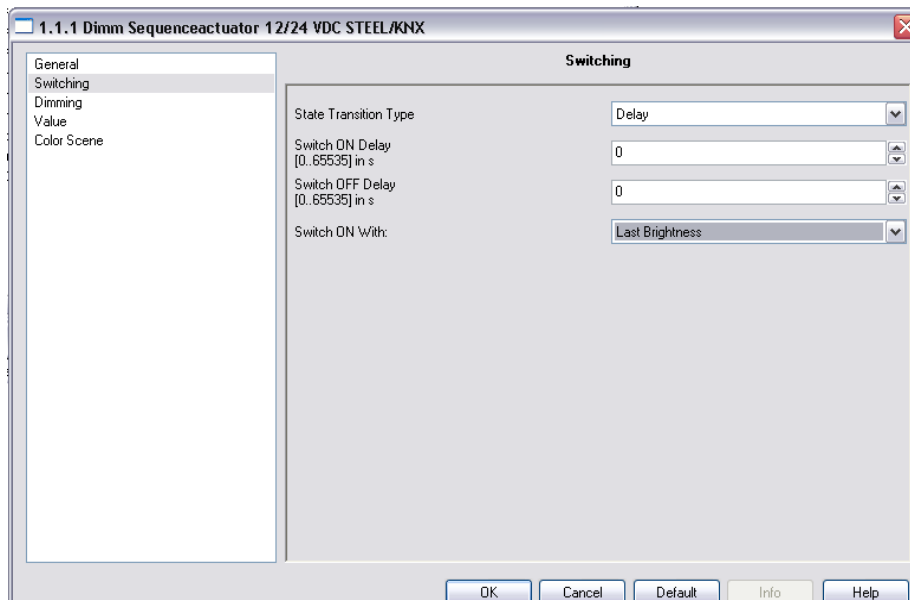
**Dimming rate for switching on**

Options: *Value between 0 and 255 seconds*

This parameter is only active when the dimming transition is activated. The value indicates the rate at which the final value should be reached after switching on.

A value of zero corresponds to immediate transition to the final value.

Dimming rate for switching off

Options: *Value between 0 and 255 seconds*

This parameter is only active when the dimming transition is activated. The value indicates the rate at which the final value should be reached after switching on.

A value of zero corresponds to immediate transition to the final value.

3.2.2 Parameter window: dimming

In this window, parameters are set to do with the relative dimming of the corresponding channels. The parameters apply to all three channels.

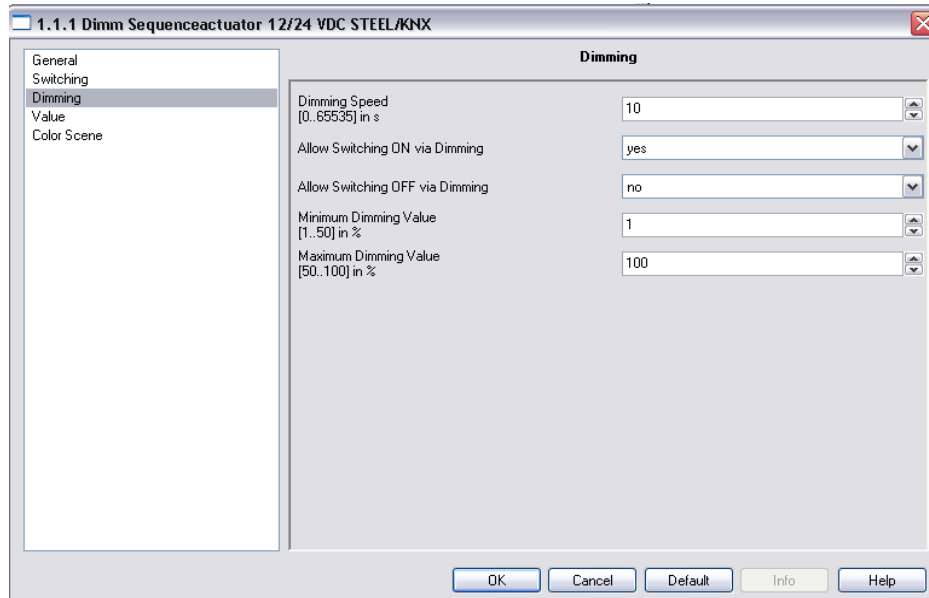

Dimming rate

Options: *A value between 0 and 65535 seconds*

The relative dimming rate, the dimming gradient, is set here.

The dimming rate is the length of time for the brightness to change from 0 % to 100 %.

Enable switching on using relative dimming

Options: *no*
 yes

If “switching on using relative dimming” is enabled, lighting that is off is made brighter, using a “dim” message.

Enable switching off using relative dimming

Options: *no*
 yes

If “switching off using relative dimming” is enabled, lighting that is on is made dimmer. The parameter value “no” causes the brightness value to remain at the lower value.

Upper dimming limit

Options: *100/99...51/50 %*

The upper dimming limit is the highest brightness level with which the dimmer can be operated using relative dimming.

Lower dimming limit

Options 50/49...20...1/0,3 %

The lower dimming limit is the lowest brightness level with which the dimmer can be operated using relative dimming. In this way the control of brightness can be prevented in areas where the lighting is switched off.

The minimum lower dimming limit is 1.

3.2.3 Parameter window: value

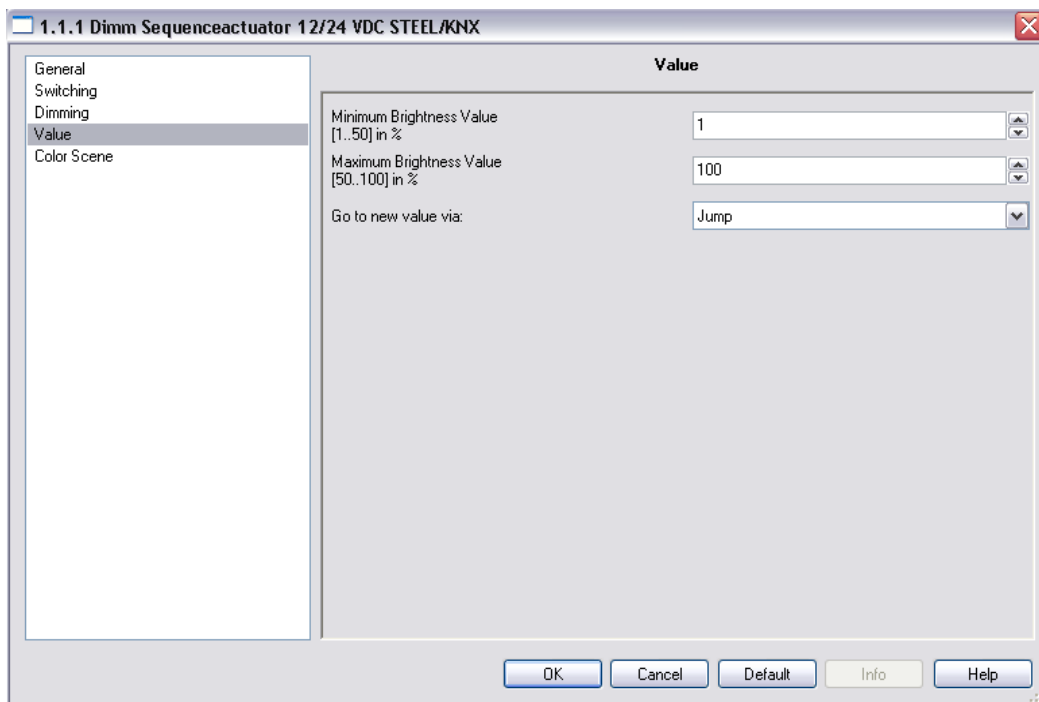

Lower limit

Options: 50/49...20...1/0,3 %

The lower limit is the brightness at which the dimmer can be operated, using a brightness level message. If the dimmer receives a brightness value below the lower dimming limit, as long as this is not 0, the lower dimmer limit is used.

Upper limit

Options: 100/99...51/50 %

The upper limit is the brightness at which the dimmer can be operated using a brightness level message. If the dimmer receives a brightness value above the upper dimming limit, the upper dimmer limit is used.

New value over..

Options: Dim

Start up

- If "dim" is selected then, using the parameter "dimming rate", dimming takes place to the new level, which is set using the menu "dim"
- If "start up" is selected then the new level is applied straight away.

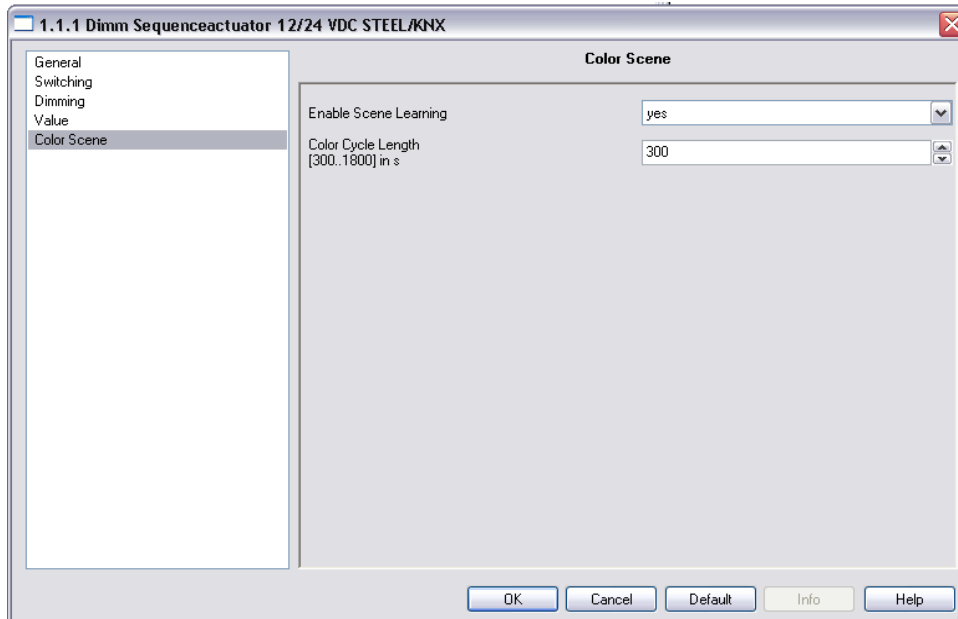
Scenes / colours**Enable scene learning**

Options: Yes
 No

Here you choose whether it is possible to store scenes or not. A scene always comprises all three outputs. Therefore you also define it specifically here as a colour scene. You can store up to 11 colour scenes.

It is possible for the unit to learn up to 11 scenes. In order to store a desired scene, the actuator needs first to activate the desired colour and brightness using the property's switch, dim, or value. Once you have the desired colour / brightness then, using the property "scene control" and choosing the number to store the scene under, it can be stored.

Important: For scene numbers 1...11 you use values 128...139 for the "scene control" property. To recall scenes, you use the numbers 1...11 using the property "scene number and scene control"

Colour cycle duration

Options: 300 to 1800 Seconds

Here you set the duration of a pre-programmed colour cycle.

The colour cycle is activated or deactivated using the property "start / stop colour cycle".

The colour cycle runs through one cycle of the RGB phases in the defined time

Definition of the colour cycle

$$t_1 = \frac{T_{ges}}{N_1 + 3 * N_2}$$

$$t_2 = 3 * t_1$$

Abbreviation	Description
t_1	Duration, short phase
t_2	Duration, long phase
T_{ges}	Total duration of the colour cycle
N_1	Number of short phases
N_2	Number of long phases

Phase	Duration (s)	Red (%)	Green (%)	Blue (%)
1	t_1	100	0	0
2	t_2	100	0 → 100	0
3	t_2	100 → 0	100	0
4	t_1	0	100	0
5	t_2	0	100	0 → 100
6	t_2	0	100 → 0	100
7	t_1	0	0	100
8	t_2	0 → 100	0	100
9	t_2	100		100 → 0

3.3 Communication properties

3.3.1 General properties

Nr.	Property name	Function	Data type	Flags
0,3,6	Switch on/off channel R Switch on/off channel G Switch on/off channel B	Switching	1 Bit DPT 1.001	
Switches the outputs on or off. 0: Command for switching off 1: Command for switching on				
1,4,7	Dimming control channel R Dimming control channel G Dimming control channel B	Relative dimming	4 Bit DPT 3.007	
Gives the commands (brighter, darker, stop) for the dimming of the outputs.				
2,5,8	Absolute value, channel R Absolute value, channel G Absolute value, channel B	Brightness level	1 Byte DPT 5.001	
Gives a brightness level to the outputs. The value can be set to be dimmed to or switched to immediately.				
9,10,11	Info on/off channel R Info on/off channel G Info on/off channel B	Switching status	1 Bit DPT 1.001	
Used to feed back the switching status of the output. 0: Output is off 1: Output is on				
12,13,14	Dimming value channel R Dimming value channel G Dimming value channel B	Brightness level status	1 Byte DPT 5.001	
Used to feedback the actual brightness level of the output. The property value updates itself regarding any switching or dimming in progress.				

3.3.2 Scene control

Nr.	Property name	Function	Data type	Flags																																			
16	Scene control	Scene control	1 Byte DPT 18.001																																				
<p>This function is active if the colour cycle is activated. Using this property, the outputs can be combined into a corresponding KNX scene. Scenes can be stored and recalled using this property. The 3 brightness values of the outputs are always applied.</p> <table border="1"> <thead> <tr> <th colspan="2">KNX message value</th> <th rowspan="2">Meaning</th> </tr> <tr> <th>decimal</th> <th>hexadecimal</th> </tr> </thead> <tbody> <tr> <td>0</td> <td>0h</td> <td>Apply scene 1</td> </tr> <tr> <td>1</td> <td>1h</td> <td>Apply scene 2</td> </tr> <tr> <td>2</td> <td>2h</td> <td>Apply scene 3</td> </tr> <tr> <td>...</td> <td>...</td> <td>...</td> </tr> <tr> <td>10</td> <td>Ah</td> <td>Apply scene 11</td> </tr> <tr> <td>128</td> <td>80h</td> <td>Store scene 1</td> </tr> <tr> <td>129</td> <td>81h</td> <td>Store scene 1</td> </tr> <tr> <td>130</td> <td>82h</td> <td>Store scene 1</td> </tr> <tr> <td>...</td> <td>...</td> <td>...</td> </tr> <tr> <td>139</td> <td>8AH</td> <td>Store scene 1</td> </tr> </tbody> </table>					KNX message value		Meaning	decimal	hexadecimal	0	0h	Apply scene 1	1	1h	Apply scene 2	2	2h	Apply scene 3	10	Ah	Apply scene 11	128	80h	Store scene 1	129	81h	Store scene 1	130	82h	Store scene 1	139	8AH	Store scene 1
KNX message value		Meaning																																					
decimal	hexadecimal																																						
0	0h	Apply scene 1																																					
1	1h	Apply scene 2																																					
2	2h	Apply scene 3																																					
...																																					
10	Ah	Apply scene 11																																					
128	80h	Store scene 1																																					
129	81h	Store scene 1																																					
130	82h	Store scene 1																																					
...																																					
139	8AH	Store scene 1																																					
15	Scene number	Scene number	1 Byte DPT 17.001																																				
<p>Calls up the scenes</p> <table border="1"> <thead> <tr> <th colspan="2">KNX message value</th> <th rowspan="2">Meaning</th> </tr> <tr> <th>decimal</th> <th>hexadecimal</th> </tr> </thead> <tbody> <tr> <td>0</td> <td>0h</td> <td>Apply scene 1</td> </tr> <tr> <td>1</td> <td>1h</td> <td>Apply scene 2</td> </tr> <tr> <td>2</td> <td>2h</td> <td>Apply scene 3</td> </tr> <tr> <td>...</td> <td>...</td> <td>...</td> </tr> <tr> <td>10</td> <td>Ah</td> <td>Apply scene 11</td> </tr> </tbody> </table>					KNX message value		Meaning	decimal	hexadecimal	0	0h	Apply scene 1	1	1h	Apply scene 2	2	2h	Apply scene 3	10	Ah	Apply scene 11															
KNX message value		Meaning																																					
decimal	hexadecimal																																						
0	0h	Apply scene 1																																					
1	1h	Apply scene 2																																					
2	2h	Apply scene 3																																					
...																																					
10	Ah	Apply scene 11																																					

3.3.3 Colour cycle

Nr.	Property name	Function	Data type	Flags
17	Start/Stop colour cycle	Start/Stop colour cycle	1 Bit DPT 1.001	
<p>Starts and stops running the colour cycle through the outputs.</p> <p>0: Stop the colour cycle 1: Start the colour cycle</p>				

HEAD OFFICE

Customer Service centre:

BILTON LED LIGHTING
Loferer straÙe.2
5760 Saalfelden/ Austria
Tel: +43 6582 71164
Fax:+43 6582 71164 -10
service@bilton.at
www.BILTON.at

Produced and tested by:
Micro Systeme GmbH
Hirnreit 113
5771 Leogang